

SUN2000-(33KTL-A, 36KTL, 42KTL) Quick Guide

Issue: 05
Part Number: 31508547
Date: 2018-03-22

HUAWEI TECHNOLOGIES CO., LTD.



NOTICE

1. The information in this document is subject to change without notice. Every effort has been made in the preparation of this document to ensure accuracy of the contents, but all statements, information, and recommendations in this document do not constitute a warranty of any kind, express or implied.
2. Before device installation, carefully read the *SUN2000-(33KTL-A, 36KTL, 42KTL) User Manual* to get familiar with product information and safety precautions.
3. Only qualified and trained electrical technicians are allowed to operate the device. Operators should understand the components and functioning of a grid-tied PV power system and be familiar with relevant local standards.
4. Before installing the device, check that deliverables are intact and complete against the *packing list*. If any damage is found or any component is missing, contact the dealer.
5. Use insulated tools when installing the device. For personal safety, wear insulation gloves and protective shoes.
6. Huawei shall not be liable for any consequence caused by violation of the storage, transportation, installation, and operation regulations specified in this document and the user manual.

1 Overview

SUN2000 Front View

- (1) PV connection indicator
- (2) Grid-tied indicator
- (3) Communication indicator
- (4) Alarm/Maintenance indicator
- (5) Maintenance compartment door
- (6) Host panel

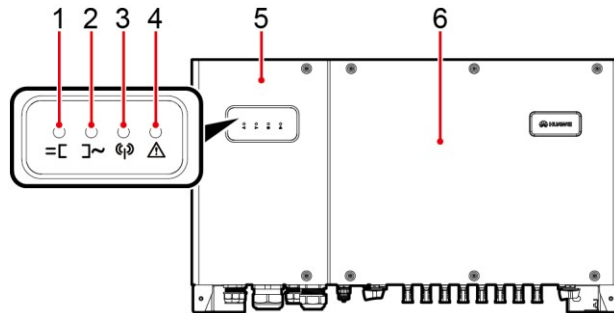

IS03WC0004

Ports

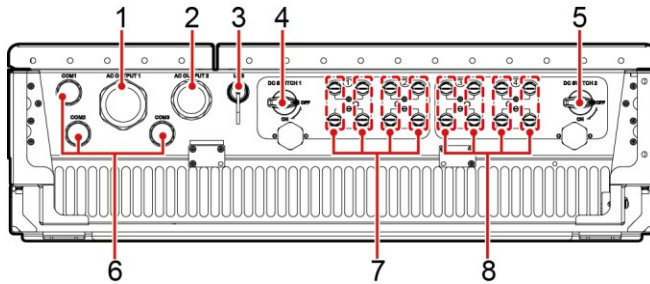

IS03WC0003

- (1) Waterproof cable connector (AC OUTPUT 1)
- (2) Waterproof cable connectors (AC OUTPUT 2)
- (3) USB port (USB)
- (4) DC switch 1 (DC SWITCH 1)
- (5) DC switch 2 (DC SWITCH 2)
- (6) Waterproof cable connectors (COM1/COM2/COM3)
- (7) DC input terminal (controlled by DC SWITCH 1)
- (8) DC input terminal (controlled by DC SWITCH 2)

NOTE

Waterproof cable connector is abbreviated as connector in the following text.

Enclosure dimensions

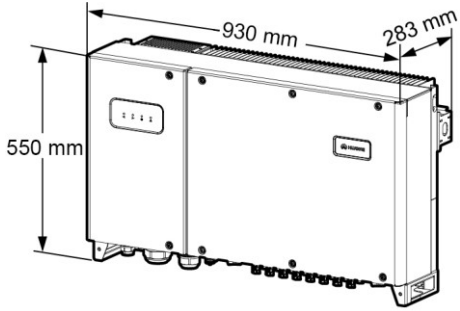

IS03WC0001

Mounting bracket dimensions

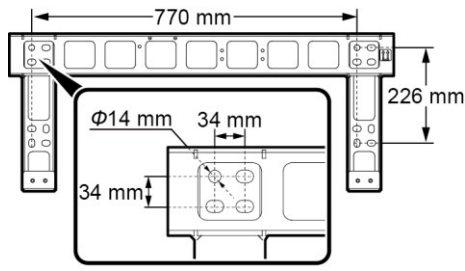

IS03WC0002

2 Installation Requirements

2.1 Installation Angle

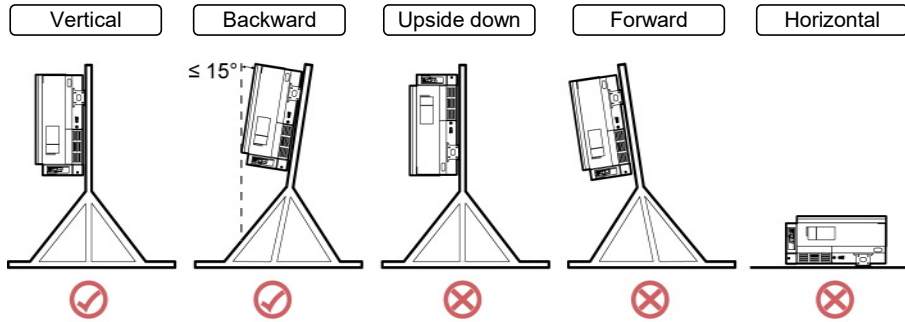

IS03HC0004

2.2 Installation Space

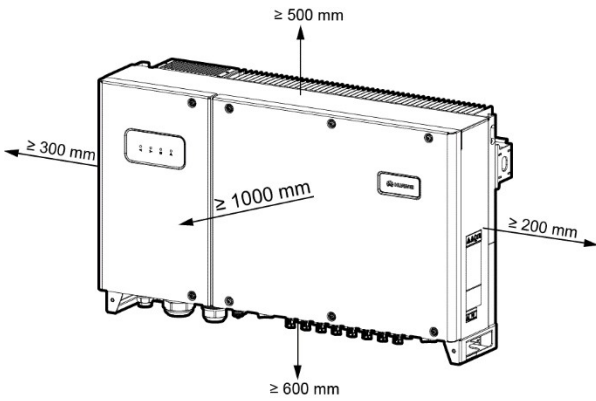

IS03SC0001

NOTE

For ease of installing the SUN2000 on the mounting bracket, connecting cables to the bottom of the SUN2000, and maintaining the SUN2000 in future, it is recommended that the bottom clearance be greater than or equal to 600 mm and less than or equal to 730 mm.

3 Installing the SUN2000

NOTE

- The SUN2000 mounting bracket has four groups of tapped holes, each group containing four tapped holes. Mark any hole in each group based on site requirements and mark four holes in total. Two round holes are preferred.
- The SUN2000 is delivered with M12x40 screw assemblies. If the screw length does not meet the installation requirements, prepare M12 screw assemblies by yourself and use them together with the delivered M12 nuts.
- The following describes how to support-mount the SUN2000 as an example. For details about how to wall-mount the SUN2000, see the *SUN2000-(33KTL-A, 36KTL, 42KTL) User Manual*.

1. Remove the security torx wrench from the mounting bracket and set it aside.

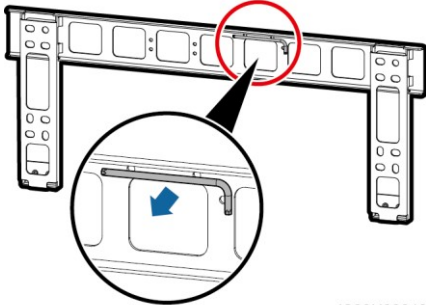

2. Mark hole positions.

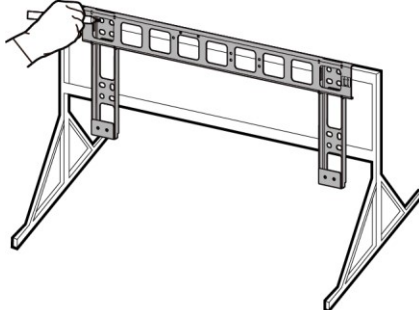

3. Drill holes. (You are advised to apply anti-rust paint on the hole positions for protection.)

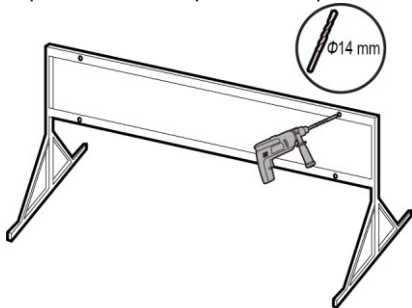

4. Secure the mounting bracket.

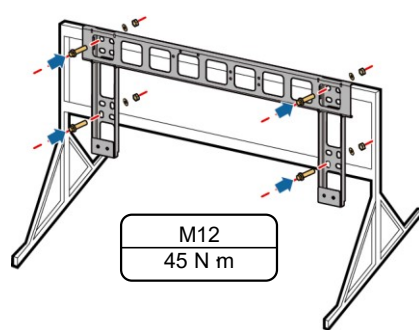

5. Install the SUN2000 on the mounting

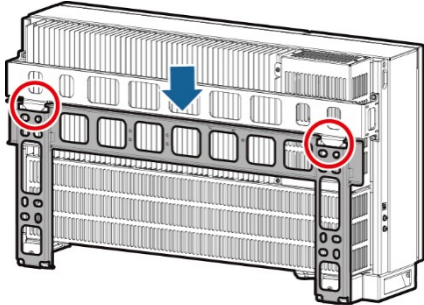

6. Tighten the security torx screws using a security torx wrench.

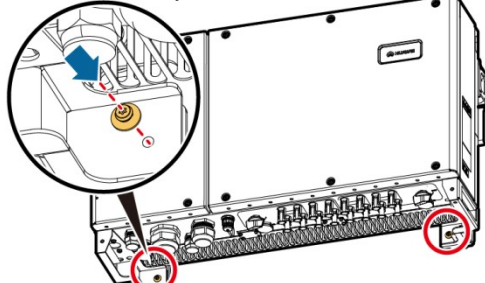

4 Electrical Connections

4.1 Preparations

NOTE

1. Before connecting cables, ensure that all required OT terminals and cables are prepared. Copper-core cables with copper wiring terminals are recommended. For the requirements on the cables and terminals made of other materials, see the *SUN2000-(33KTL-A, 36KTL, 42KTL) User Manual*.
2. The SUN2000-42KTL supports the 3W+PE wiring mode.
3. The SUN2000-33KTL-A/36KTL supports 3W+PE and 3W+N+PE wiring modes. Connect the neutral wire if required.

No.	Name	Model or Specifications	Quantity	Function
1	OT terminal	M6	1 PCS	Connects to a ground cable.
2	OT terminal	M8	3 PCS	Connects to an AC output power cable.
3	Ground cable	Outdoor copper-core cable with a cross-sectional area of 16 mm ²	N/A	Connects to a ground cable.
4	AC output power cable	<ul style="list-style-type: none">• Outdoor copper-core cable with a cross-sectional area of 16 mm² (for the SUN2000-33KTL-A)• Outdoor copper-core cable with a cross-sectional area of 25 mm² (for the SUN2000-36KTL/42KTL)	N/A	Connects to an AC output power cable.
5	DC input power cable	PV1-F/4 mm ²	N/A	Connects to a DC input power cable.
6	RS485 communications cable	Computer cable DJYP2VP2-22 2x2x1	N/A	Connects to an RS485 communications cable over a terminal block.
		Outdoor shielded network cable CAT 5E	N/A	Connects to an RS485 communications cable over an RJ45 network port.
7	FE communications cable	Outdoor shielded network cable CAT 5E	N/A	Connects to an Ethernet communications cable over an FE network port.
8	Cable tie	N/A	Based on site requirements	Binds cables.

4.2 Installing Ground Cables

- The ground point on the enclosure is preferred to connect to the PE cable for the SUN2000.
- The ground point in the maintenance compartment is mainly used for connecting to the ground cable included in the multi-core AC power cable. For details, see section 4.3 "Installing AC Output Power Cables."

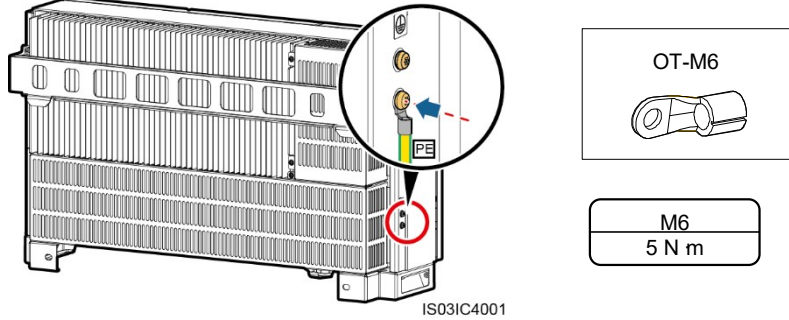

NOTE

1. The outdoor copper-core cable with a cross-sectional area of 16 mm² is recommended. The ground cable must be secured.
2. It is recommended that ground cable of the SUN2000 be connected to the nearest ground point. For a system with multiple SUN2000s connected in parallel, connect the ground points of all SUN2000s to ensure equipotential connections to ground cables.
3. To enhance the corrosion resistance of the ground terminal, apply silica gel or paint on it after connecting the ground cable.

4.3 Installing AC Output Power Cables

WARNING

1. Never open the host panel of the SUN2000.
2. Before opening the SUN2000 maintenance compartment door, turn off the downstream AC output switch and the two bottom DC switches.

NOTE

- If you connect a ground cable to the ground point on the enclosure shell, you are recommended to use a three-core outdoor copper-core cable with a cross-sectional area of 25 mm² as the AC output power cable for the SUN2000-42KTL.
- If you connect a ground cable to the ground point in the maintenance compartment, you are recommended to use a four-core outdoor copper-core cable with a cross-sectional area of 25 mm² as the AC output power cable for the SUN2000-42KTL.
- If you connect a ground cable to the ground point on the enclosure shell in a scenario without a neutral wire, you are recommended to use a three-core outdoor copper-core cable with a cross-sectional area of 16 mm² as the AC output power cable for the SUN2000-33KTL-A and a three-core outdoor copper cable with a cross-sectional area of 25 mm² as the AC output power cable for the SUN2000-36KTL.
- If you connect a ground cable to the ground point in the maintenance compartment in a scenario without a neutral wire, you are recommended to use a four-core outdoor copper-core cable with a cross-sectional area of 16 mm² as the AC output power cable for the SUN2000-33KTL-A and a four-core outdoor copper cable with a cross-sectional area of 25 mm² as the AC output power cable for the SUN2000-36KTL.

 **NOTE**

- If you connect a ground cable to the ground point on the enclosure shell in a scenario with a neutral wire, you are recommended to use a four-core outdoor copper-core cable with a cross-sectional area of 16 mm² as the AC output power cable for the SUN2000-33KTL-A and a four-core outdoor copper cable with a cross-sectional area of 25 mm² as the AC output power cable for the SUN2000-36KTL.
- If you connect a ground cable to the ground point in the maintenance compartment in a scenario with a neutral wire, you are recommended to use a five-core outdoor copper-core cable with a cross-sectional area of 16 mm² as the AC output power cable for the SUN2000-33KTL-A and a five-core outdoor copper cable with a cross-sectional area of 25 mm² as the AC output power cable for the SUN2000-36KTL.
- For more details about cable specifications, see the *SUN2000-(33KTL-A, 36KTL, 42KTL) User Manual*.
- The AC OUTPUT 1 connector supports the cable with an outer diameter of 18 mm to 44 mm.

1. Remove the two security torx screws from the maintenance compartment door using a security torx wrench. (Set the two screws aside. Use the idle ground screw on the enclosure shell as the standby screw, and the idle floating nut on the enclosure as the standby floating nut.)

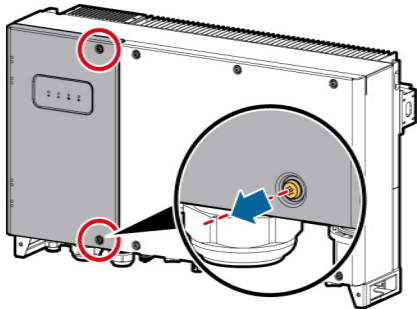

IS03HC0009

2. Open the maintenance compartment door and adjust the support bar. (The support bar is bound to the enclosure base.)

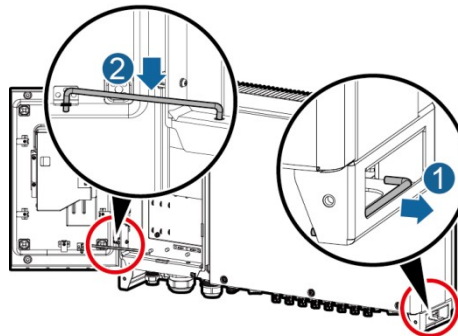

IS03H00056

3. Remove the AC terminal cover.

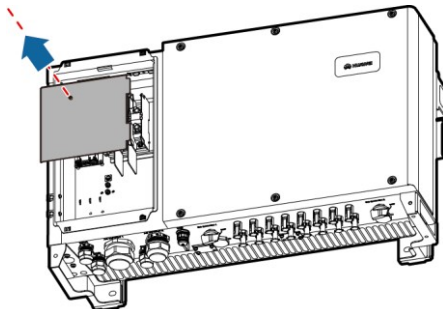

IS03HC0007

4. Remove the locking cap from the AC OUTPUT 1 connector and then remove the plug.
5. Select an appropriate rubber fitting based on the cable outer diameter. Route the cable through the locking cap and then the rubber fitting.

NOTICE

- Mismatch between the cable outer diameter and the rubber fitting may degrade the Ingress Protection Rating of the device.
- To avoid damaging the rubber fitting, do not route a cable with a crimped OT terminal directly through the rubber fitting.
- Do not adjust the cable when the locking cap is tightened. Otherwise, the rubber fitting will shift, which affects the Ingress Protection Rating of the device.

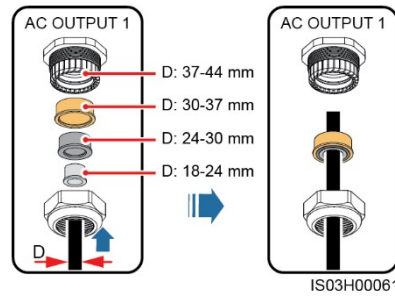

6. Remove an appropriate length of the jacket and insulation layer from the AC output power cable using a wire stripper. (Ensure that the jacket is in the maintenance compartment.)

- a. Three-core cable (excluding the ground cable and neutral wire)

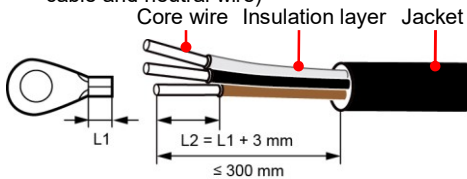

- b. Four-core cable (including the ground cable but excluding the neutral wire)

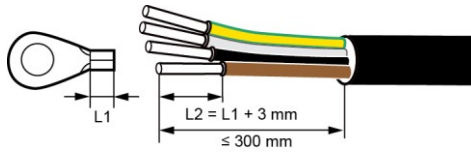

- c. Four-core cable (excluding the ground cable but including the neutral wire)

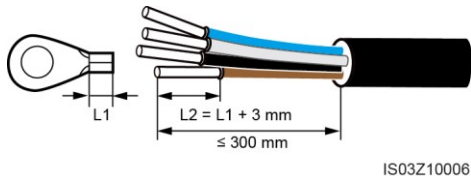

- d. Five-core cable (including the ground cable and neutral wire)

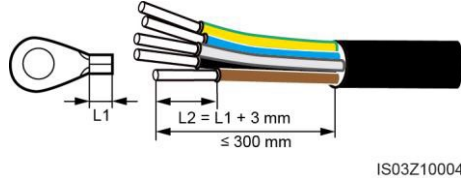

7. Insert the exposed core wires into the crimping area of the OT terminal and crimp them using hydraulic pliers.
8. Wrap the wire crimping area with heat shrink tubing or PVC insulation tape.

NOTICE

If heat shrink tubing is used, route the AC output power cable through the heat shrink tubing and then crimp the OT terminal. Ensure that the area wrapped by the heat shrink tubing does not exceed the crimping area of the OT terminal.

9. Route the AC output power cable through the AC OUTPUT 1 connector at the bottom of the enclosure.
10. Connect the AC output power cable to the AC terminal block, and then secure the connector using a 13 mm socket wrench with an extension rod. If you connect a ground cable to the ground point in the maintenance compartment, tighten the ground screw using a 10 mm socket wrench with an extension rod.

NOTICE

- Ensure that the AC output power cable is connected securely. Otherwise, the SUN2000 may fail to operate or experience a fault that will damage the terminal block. For example, the SUN2000 may generate heat during operation due to unreliable connection.
- If the SUN2000 is insecurely installed and the AC output power cable bears the pulling force, ensure that the last cable bearing the force is the PE cable.

a. 3-pin SUN2000-42KTL
(excluding the ground cable)

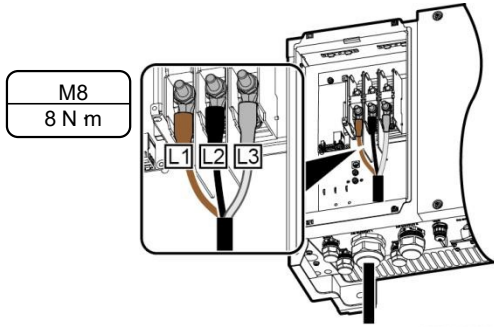

b. 3-pin SUN2000-42KTL
(including the ground cable)

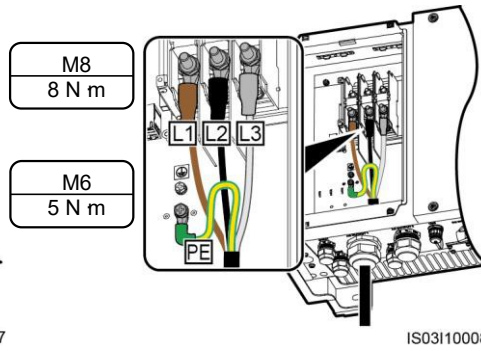

c. 4-pin SUN2000-42KTL (excluding the
ground cable and neutral wire)

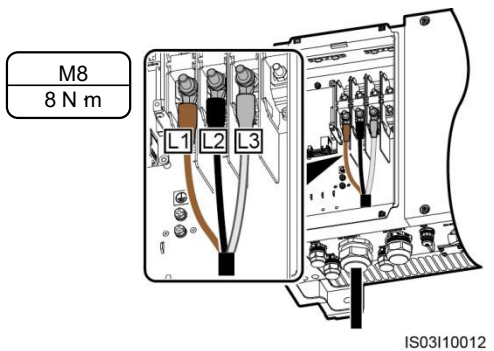

d. 4-pin SUN2000-42KTL (including the
ground cable but excluding the neutral
wire)

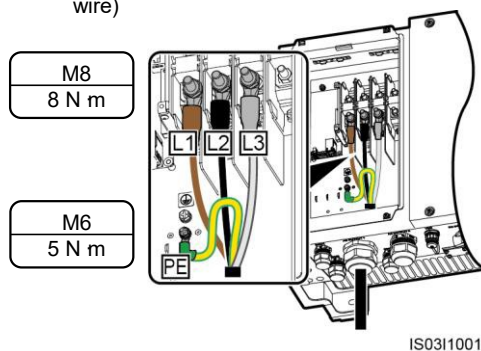

e. SUN2000-33KTL-A/36KTL (excluding
the ground cable and neutral wire)

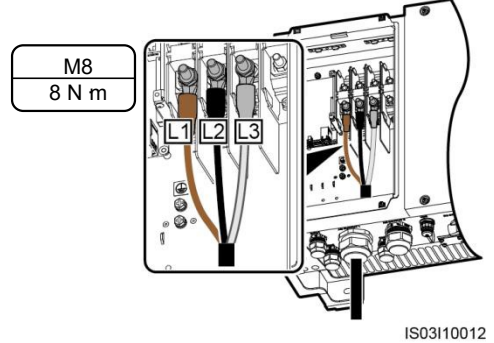

f. SUN2000-33KTL-A/36KTL (including
the ground cable but excluding the
neutral wire)

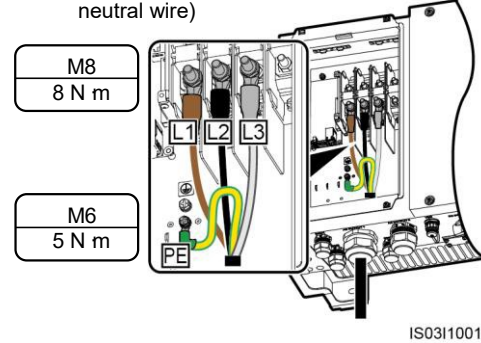

g. SUN2000-33KTL-A/36KTL (excluding the ground cable but including the neutral wire)

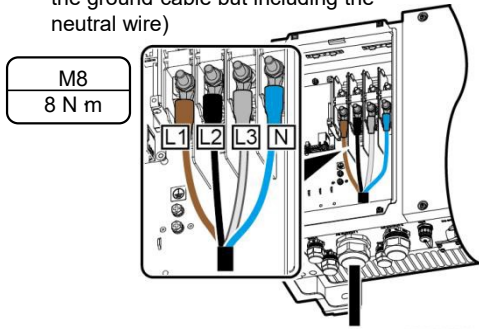

h. SUN2000-33KTL-A/36KTL (including the ground cable and neutral wire)

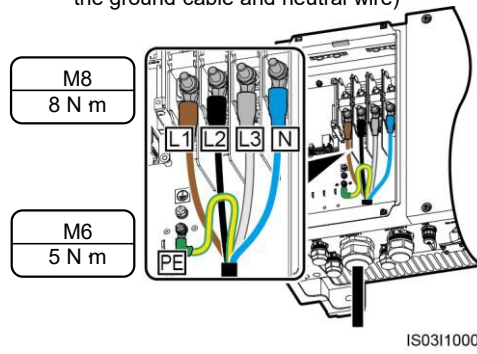

11. Use a torque wrench with an open end of 65 mm to tighten the locking cap to a torque of 7.5 N m, and seal the waterproof connector.

4.4 Installing DC Input Power Cables

Selecting DC input terminals

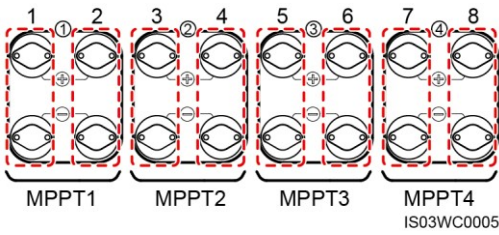

NOTE

The SUN2000 provides two DC switches, namely, DC SWITCH 1 and DC SWITCH 2. DC SWITCH 1 controls the first to fourth routes of DC input terminals, whereas DC SWITCH 2 controls the fifth to eighth routes of DC input terminals.

Number of Inputs	SUN2000
1	Connects to any route.
2	Connects to routes 1 and 5.
3	Connects to routes 1, 3, and 5.
4	Connects to routes 1, 3, 5, and 7.
5	Connects to routes 1, 2, 3, 5, and 7.
6	Connects to routes 1, 2, 3, 5, 6, and 7.
7	Connects to routes 1, 2, 3, 4, 5, 6, and 7.
8	Connects to routes 1, 2, 3, 4, 5, 6, 7, and 8.

! WARNING

- Ensure that the PV module output is well insulated to ground.
- Before inserting the positive and negative connectors respectively into the positive and negative DC input terminals of the SUN2000, check that the DC voltage does not exceed 1100 V DC using a multimeter and that the cables are connected correctly. Otherwise, the SUN2000 will be damaged.

! NOTICE

1. Use the positive and negative metal contacts and DC connectors supplied with the SUN2000. Using other models of positive and negative metal contacts and DC connectors may result in serious consequences. The caused device damage is not covered under any warranty or service agreement.
2. The metal contacts supplied with the DC connectors are either cold forming contacts or stamping forming contacts. Crimp the metal cold forming contacts using crimping tool H4TC0001 (Amphenol). Crimp the metal stamping contacts using crimping tool H4TC0002 (Amphenol). Choose the crimping tools that fit the metal contact types. Do not mix up the tools.
3. Before connecting DC input power cables, label the cable polarities to ensure correct cable connections. If the cables are connected incorrectly, the SUN2000 may be damaged.
4. Insert the crimped metal contacts of the positive and negative power cables into the appropriate positive and negative connectors. Then pull back the DC input power cables to ensure that they are connected securely.
5. Connect the positive and negative connectors to the appropriate positive and negative DC input terminals. Then pull back the DC input power cables to ensure that they are connected securely.
6. If the DC input power cable is reversely connected, do not operate the DC switches and positive and negative connectors immediately. Otherwise, the SUN2000 will be damaged. The caused equipment damage is beyond the warranty scope. Wait until the solar irradiance declines at night and the PV string current reduces to below 0.5 A. Then, turn off the two DC switches, remove the positive and negative connectors, and correct the polarity of the DC input power cable.

Installing a DC input power cable (using metal cold forming contacts)

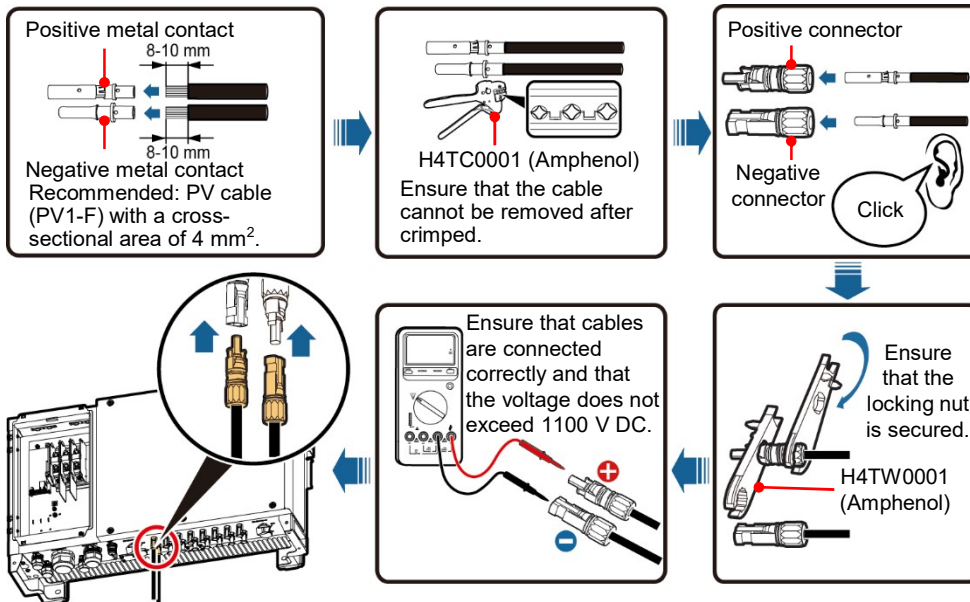

IS03IC1002

Installing a DC input power cable (using metal stamping forming contacts)

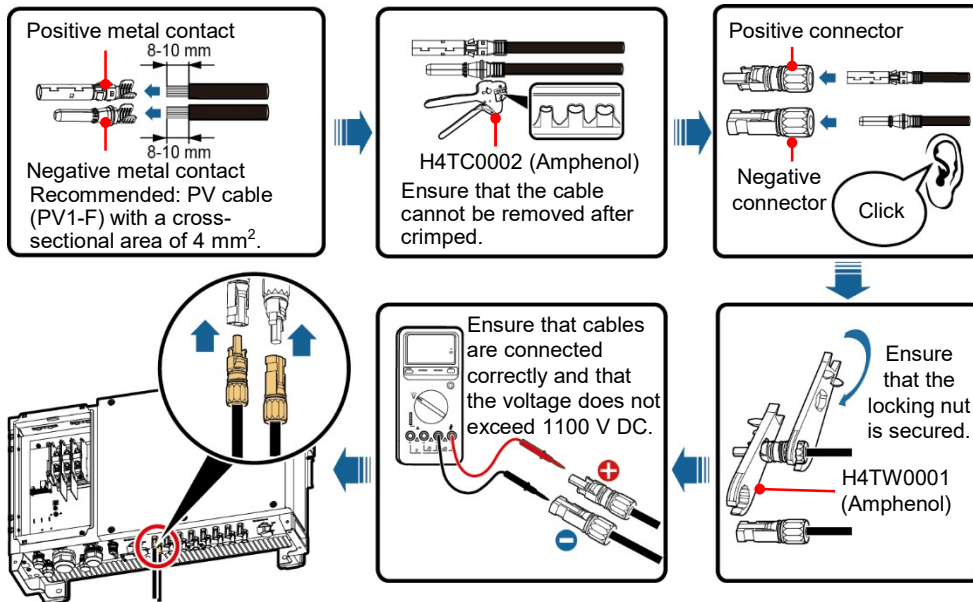

IS03I20023

4.5 Selecting a Communication Mode

1. You can choose either the PLC or RS485 communication mode for the SUN2000-33KTL-A/36KTL/42KTL.
2. FE communication is optional for the SUN2000-36KTL. If you need to use the FE communication mode, contact local technical support.
3. If the SUN2000-36KTL adopts FE communication mode, it supports only RS485 and FE communication modes, and does not support PLC communication mode.

NOTE

- If PLC is used, you do not have to connect any cable to the SUN2000, but have to connect AC power cables to the PLC CCO module or SmartLogger2000. For detailed operations, see the *PLC CCO01A User Manual* or *SmartLogger2000 User Manual*.
- If RS485 is used, do not connect the PLC CCO module to the AC power cable.

4.6 Installing RS485 Communications Cables

NOTICE

1. When routing communications cables, separate communications cables from power cables to prevent communication from being affected.
2. An RS485 cable can connect to either a terminal block or an RJ45 network port. It is recommended that the RS485 cable connect to a terminal block.

Connecting to a terminal block (recommended)

The DJYP2VP2-22 2x2x1 computer cable or a communications cable with a cross-sectional area of 1 mm² and outer diameter of 14–18 mm is recommended.

1. Remove an appropriate length of the jacket and core wire insulation layer from the communications cable using a wire stripper.

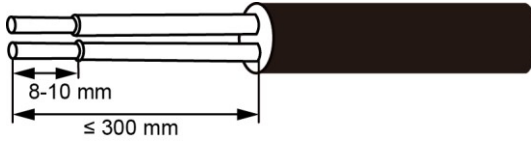

IS03ZC0001

2. Remove the locking caps from the COM1 and COM2 connectors at the SUN2000 bottom and then remove the plugs from the caps.
3. Route the communications cables through the locking caps, and then the COM1 (RS485 IN) and COM2 (RS485 OUT) connectors at the SUN2000 bottom.
4. Remove the terminal base from the terminal block, and connect the communications cables to the terminal base.

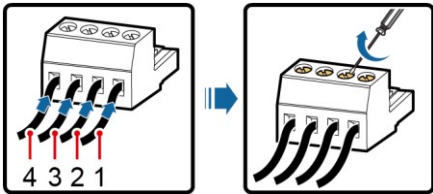

IS03IC1004

No.	Port Definition	Description
1	RS485A IN	RS485A, RS485 differential signal +
2	RS485A OUT	RS485A, RS485 differential signal +
3	RS485B IN	RS485B, RS485 differential signal -
4	RS485B OUT	RS485B, RS485 differential signal -

5. Install the terminal base on the terminal block, and connect the shield layer to the ground point.
6. Bind the communications cables.

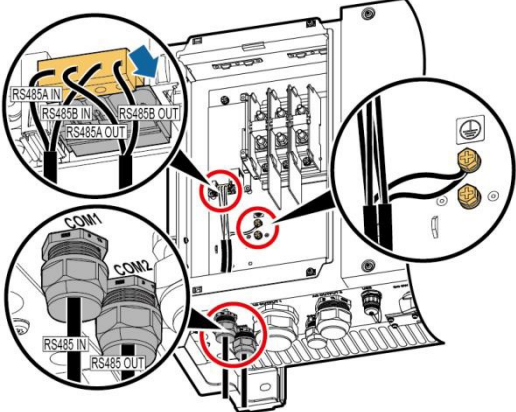

IS03110027

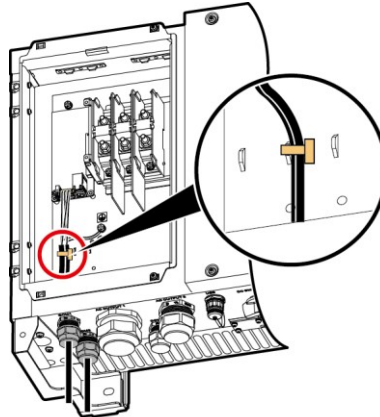

IS03W00013

NOTE

When connecting the shielded cables, choose whether to crimp the OT terminal based on site requirements.

7. Use a torque wrench with an open end of 33 mm to tighten the locking cap to a torque of 7.5 N m, and seal the waterproof connector.

RJ45 network port connection

You are recommended to use a CAT 5E outdoor shielded network cable with an outer diameter less than 9 mm and internal resistance not greater than 1.5 ohms/10 m, as well as a shielded RJ45 connector.

1. Insert the wires of the network cable to the RJ45 connector in sequence.
2. Crimp the RJ45 connector using a crimping tool.

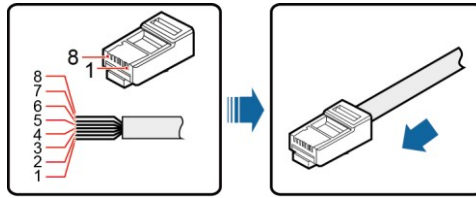

IS01ZC0021

No.	Color	Pin Definition
1	White-and-orange	RS485A, RS485 differential signal +
2	Orange	RS485B, RS485 differential signal -
3	White-and-green	N/A
4	Blue	RS485A, RS485 differential signal +
5	White-and-blue	RS485B, RS485 differential signal -
6	Green	N/A
7	White-and-brown	N/A
8	Brown	N/A

3. Remove the locking cap from the COM1 connector at the SUN2000 bottom and then remove the plug from the cap.
4. Route the communications cables through the locking cap and then the COM1 connector at the SUN2000 bottom.
5. Insert the RJ45 connector into the RJ45 network port
6. Bind the communications cables.

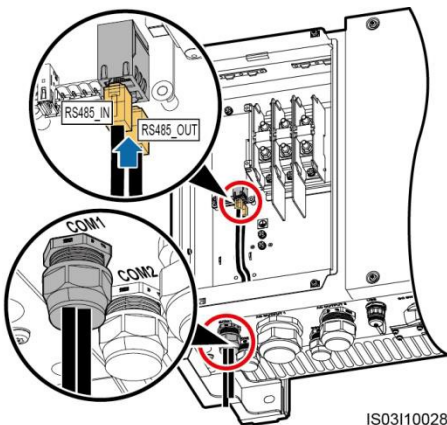

IS03110028

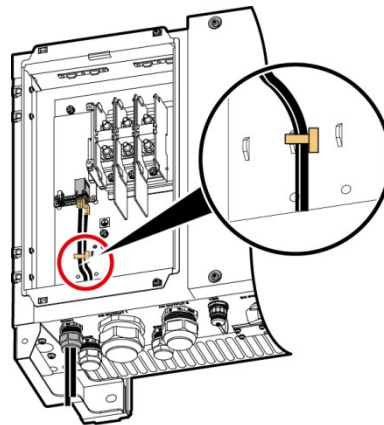

IS03W00014

7. Use a torque wrench with an open end of 33 mm to tighten the locking cap to a torque of 7.5 N m, and seal the waterproof connector.

4.7 (Optional) Installing FE Communications Cables

FE communication is mainly used in distributed rooftop scenarios with a small number of SUN2000s. The SUN2000 can directly connect to the PC over the Ethernet to implement monitoring networking.

NOTE

1. If FE communication is used, a maximum of ten SUN2000s can be connected. In addition, the NetEco needs to be installed on the PC for monitoring networking.
2. A standard network cable has two wire sequence standards, namely, 568A and 568B. The network cables used in the same PV grid-tied power generation system should comply with the same wire sequence standard.

You are recommended to use a CAT 5E outdoor shielded network cable with an outer diameter less than 9 mm and internal resistance not greater than 1.5 ohms/10 m, as well as a shielded RJ45 connector.

1. Insert the wires of the network cable to the RJ45 connector in sequence.
2. Crimp the RJ45 connector using a crimping tool.

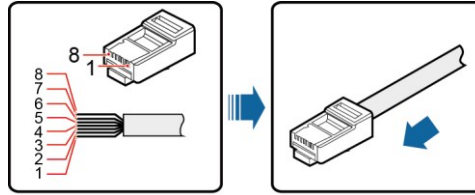

IS01ZC0021

a. 568A standard

No.	Color
1	White-and-green
2	Green
3	White-and-orange
4	Blue
5	White-and-blue
6	Orange
7	White-and-brown
8	Brown

b. 568B standard

No.	Color
1	White-and-orange
2	Orange
3	White-and-green
4	Blue
5	White-and-blue
6	Green
7	White-and-brown
8	Brown

3. Remove the locking cap from the COM1 connector at the SUN2000 bottom and then remove the plug from the cap.
4. Route the communications cables through the locking cap and then the COM1 connector at the SUN2000 bottom.

5. Insert the RJ45 connector into the FE network port in the maintenance compartment of the SUN2000.

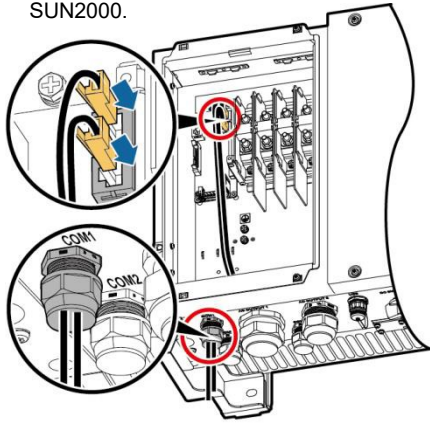

IS03I40010

6. Bind the communications cables.

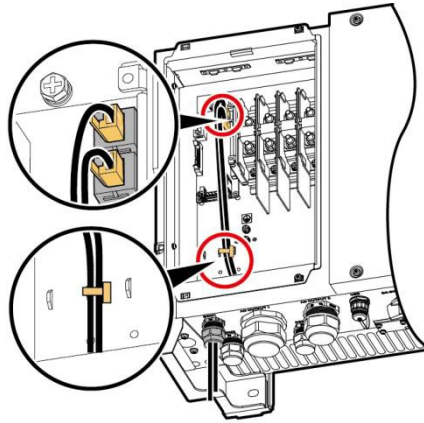

IS03I40013

7. Use a torque wrench with an open end of 33 mm to tighten the locking cap to a torque of 7.5 N m, and seal the waterproof connector.

5 Verifying the Installation

1. The SUN2000 is installed correctly and securely.	Yes <input type="checkbox"/> No <input type="checkbox"/> N/A <input type="checkbox"/>
2. The DC switches and downstream AC output switch are OFF.	Yes <input type="checkbox"/> No <input type="checkbox"/> N/A <input type="checkbox"/>
3. Ground cables are connected correctly and securely, without open circuits or short circuits.	Yes <input type="checkbox"/> No <input type="checkbox"/> N/A <input type="checkbox"/>
4. AC output power cables are connected correctly and securely, without open circuits or short circuits.	Yes <input type="checkbox"/> No <input type="checkbox"/> N/A <input type="checkbox"/>
5. DC input power cables are connected correctly and securely, without open circuits or short circuits.	Yes <input type="checkbox"/> No <input type="checkbox"/> N/A <input type="checkbox"/>
6. The communications cables are connected correctly and securely.	Yes <input type="checkbox"/> No <input type="checkbox"/> N/A <input type="checkbox"/>
7. All the connectors in use at the bottom of the enclosure are sealed.	Yes <input type="checkbox"/> No <input type="checkbox"/> N/A <input type="checkbox"/>
8. The AC terminal cover is reinstalled.	Yes <input type="checkbox"/> No <input type="checkbox"/> N/A <input type="checkbox"/>
9. The maintenance compartment door is closed and the door screws are tightened.	Yes <input type="checkbox"/> No <input type="checkbox"/> N/A <input type="checkbox"/>
10. The idle DC input terminals are sealed.	Yes <input type="checkbox"/> No <input type="checkbox"/> N/A <input type="checkbox"/>
11. The idle USB port is plugged with a waterproof plug.	Yes <input type="checkbox"/> No <input type="checkbox"/> N/A <input type="checkbox"/>
12. Idle AC OUTPUT and COM connectors are plugged and the locking caps are tightened.	Yes <input type="checkbox"/> No <input type="checkbox"/> N/A <input type="checkbox"/>

6 Powering On the System

NOTICE





Before turning on the AC switch between the SUN2000 and the power grid, use a multimeter to check that the AC voltage is within the specified range.

1. Turn on the AC switch between the SUN2000 and the power grid.
2. Ensure that the DC switches at the SUN2000 bottom are ON.
3. (Optional) Measure the temperatures at the joints between DC terminals and connectors using a point-test thermometer.

 **NOTE**

To ensure that the DC terminals are in good contact, check the temperatures at the joints between DC terminals and connectors after the SUN2000 has been running for a period of time. Ensure that the temperature rise does not exceed 40°C.

4. Observe the indicators to check the SUN2000 operating status.

Indicator	Status	Meaning	
PV connection indicator 	Green on	At least one PV string is properly connected, and the DC input voltage of the corresponding MPPT circuit is higher than or equal to 200 V.	
	Green off	The SUN2000 disconnects from all PV strings, or the DC input voltage of each MPPT circuit is less than 200 V.	
Grid-tied indicator 	Green on	The SUN2000 has connected to the power grid.	
	Green off	The SUN2000 has not connected to the power grid.	
Communications indicator 	Blinking green (on for 0.5s and then off for 0.5s)	The SUN2000 receives data over RS485/PLC/FE communication.	
	Green off	The SUN2000 has not received data over RS485/PLC/FE communication for 10 seconds.	
Alarm/Maintenance indicator 	Alarm status	Blinking red at long intervals (on for 1s and then off for 4s).	A warning alarm is generated.
		Blinking red at short intervals (on for 0.5s and then off for 0.5s).	A minor alarm is generated.
		Steady red	A major alarm is generated.
	Local maintenance status	Blinking green at long intervals (on for 1s and then off for 1s)	Local maintenance is in progress.
		Blinking green at short intervals (on for 0.125s and then off for 0.125s)	Local maintenance fails.
		Steady green	Local maintenance succeeds.

7 SUN2000 App

NOTE

1. The SUN2000 app enables the SUN2000 to communicate with the monitoring system through a USB data cable or Bluetooth for you to query alarms, configure parameters, and perform routine maintenance. The SUN2000 app is a convenient platform for local monitoring and maintenance. The app name is SUN2000.
2. Mobile phone operating system: Android 4.0 or later, iOS 7.0 or later. When the iOS is used, the app supports only Bluetooth connection.
3. Access the Huawei app store (<http://appstore.huawei.com>), Google Play (<https://play.google.com>), or App Store (iOS), search for SUN2000, and download the SUN2000 app installation package.
4. Connect a USB data cable or a Bluetooth module to the USB port of the SUN2000 to implement the communication between the SUN2000 and the app.

Bluetooth module connection

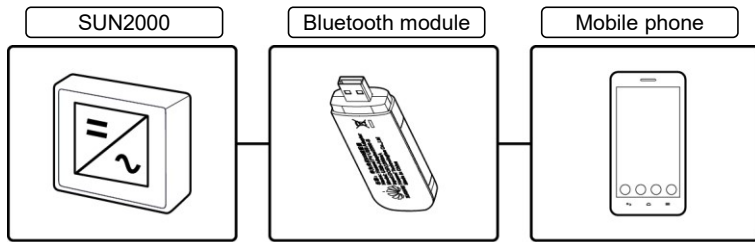

IS01NC0009

Data cable connection

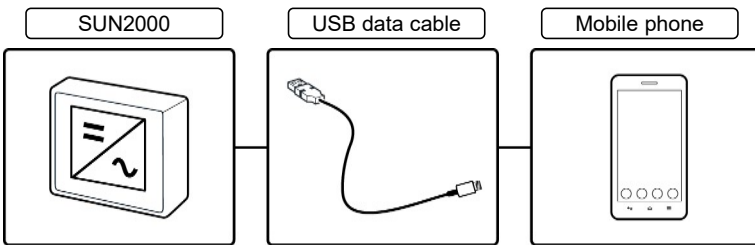

IS01NC0010

Login screen



Select a connection mode

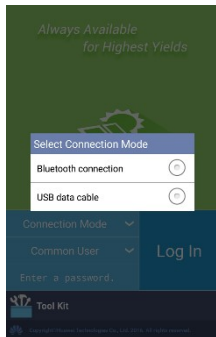

Connect Bluetooth



Switch between users

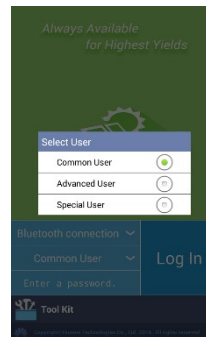

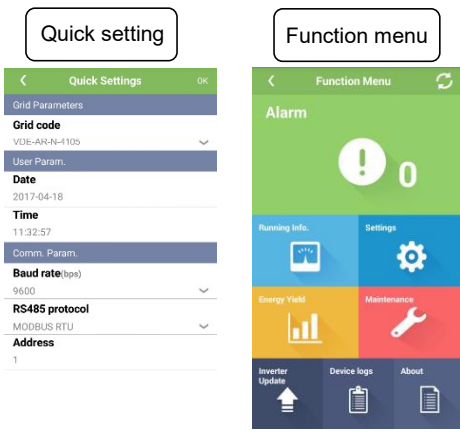

NOTICE

- The preset password for **Common User**, **Advanced User**, and **Special User** is **00000a**.
- Use the preset password upon initial login. To ensure account security, change the password immediately after login.
- The screenshots in this document correspond to app 2.1.20.101 (Android).

NOTE

Set the correct grid code based on the application area and scenario of the SUN2000.

8 Common Faults and Troubleshooting

Symptom	Possible Cause	Suggestion
String Reverse	The PV string cables are connected reversely during the SUN2000 installation.	Wait until the solar irradiance declines at night and the PV string current reduces to below 0.5 A. Then, turn off the two DC switches, remove the positive and negative connectors, and correct the polarity of the DC input power cable.

Appendix 1: Power Grid Codes (SUN2000-33KTL-A)

No.	Power Grid Code	Description	No.	Power Grid Code	Description
1	VDE-AR-N-4105	Germany low-voltage power grid	2	UTE C 15-712-1(A)	France mainland low-voltage power grid
3	UTE C 15-712-1(B)	France islands 230 V 50 Hz	4	UTE C 15-712-1(C)	France islands 230 V 60 Hz
5	CEI0-21	Italy low-voltage power grid	6	RD1699/661	Spain low-voltage power grid
7	PO12.3	Spain low-voltage power grid	8	CEI0-16	Italy low-voltage power grid
9	EN50438-TR	Turkey low-voltage power grid	N/A	N/A	N/A

Appendix 2: Power Grid Codes (SUN2000-36KTL)

No.	Power Grid Code	Description	No.	Power Grid Code	Description
1	VDE-AR-N-4105	Germany low-voltage power grid	2	NB/T 32004	China low-voltage power grid
3	UTE C 15-712-1(A)	France mainland low-voltage power grid	4	UTE C 15-712-1(B)	France islands 230 V 50 Hz
5	UTE C 15-712-1(C)	France islands 230 V 60 Hz	6	BDEW-MV	Germany medium-voltage power grid (BDEW-MV)
7	G59-England	England 230 V power grid (I > 16 A)	8	G59-Scotland	Scotland 240 V power grid (I > 16 A)

No.	Power Grid Code	Description	No.	Power Grid Code	Description
9	CEI0-21	Italy low-voltage power grid	10	EN50438-CZ	Czech Republic low-voltage power grid
11	RD1699/661	Spain low-voltage power grid	12	RD1699/661-MV480	Spain medium-voltage power grid
13	C10/11	Belgium low-voltage power grid	14	AS4777	Australia low-voltage power grid
15	IEC61727	IEC61727 low-voltage power grid (50 Hz)	16	CEI0-16	Italy low-voltage power grid
17	TAI-MEA	Thailand low-voltage power grid (MEA)	18	TAI-PEA	Thailand low-voltage power grid (PEA)
19	BDEW-MV480	Germany medium-voltage power grid (BDEW-MV480)	20	G59-England-MV480	England 480 V medium-voltage power grid (I > 16 A)
21	IEC61727-MV480	IEC61727 medium-voltage power grid (50 Hz)	22	UTE C 15-712-1-MV480	France medium-voltage power grid
23	TAI-PEA-MV480	Thailand medium-voltage power grid (PEA)	24	TAI-MEA-MV480	Thailand medium-voltage power grid (MEA)
25	EN50438-DK-MV480	Denmark medium-voltage power grid	26	EN50438-TR-MV480	Turkey medium-voltage power grid
27	EN50438-TR	Turkey low-voltage power grid	28	C11/C10-MV480	Belgium medium-voltage power grid
29	Philippines	Philippines low-voltage power grid	30	Philippines-MV480	Philippines medium-voltage power grid
31	EN50438-NL	Netherlands power grid	32	NRS-097-2-1	South Africa low-voltage power grid
33	NRS-097-2-1-MV480	South Africa medium-voltage power grid	34	KOREA	South Korea low-voltage power grid
35	IEC61727-60 Hz	IEC61727 low-voltage power grid (60 Hz)	36	IEC61727-60 Hz-MV480	IEC61727 medium-voltage power grid (60 Hz)
37	ANRE	Romania low-voltage power grid	38	ANRE-MV480	Romania medium-voltage power grid
39	PO12.3-MV480	Spain medium-voltage power grid	40	EN50438_IE-MV480	Ireland medium-voltage power grid (EN50438_IE)

No.	Power Grid Code	Description	No.	Power Grid Code	Description
41	EN50438_IE	Ireland low-voltage power grid (EN50438_IE)	42	INDIA	India low-voltage power grid
43	CEI0-16-MV480	Italy medium-voltage power grid (CEI0-16)	44	PO12.3	Spain low-voltage power grid
45	CEI0-21-MV480	Italy medium-voltage power grid (CEI0-21)	46	Egypt ETEC	Egypt low-voltage power grid
47	Egypt ETEC-MV480	Egypt medium-voltage power grid	48	CLC/TS50549_IE	Ireland low-voltage power grid (CLC/TS50549_IE)
49	CLC/TS50549_IE-MV480	Ireland medium-voltage power grid (CLC/TS50549_IE)	50	Jordan-Transmission	Jordan low-voltage power grid
51	Jordan-Transmission-MV480	Jordan medium-voltage power grid	52	NAMIBIA	Namibia power grid
53	ABNT NBR 16149	Brazil low-voltage power grid	54	SA_RPPs	South Africa low-voltage power grid
55	SA_RPPs-MV480	South Africa medium-voltage power grid	56	ZAMBIA	Zambia low-voltage power grid
57	Chile	Chile low-voltage power grid	58	Mexico-MV480	Mexico medium-voltage power grid
59	Malaysian	Malaysia low-voltage power grid	60	KENYA_ETHIOPIA	Kenya low-voltage and Ethiopia low-voltage power grid
61	NIGERIA	Nigeria low-voltage power grid	62	NIGERIA-MV480	Nigeria medium-voltage power grid
63	DUBAI	Dubai low-voltage power grid	64	DUBAI-MV480	Dubai medium-voltage power grid
65	Northern Ireland	Northern Ireland low-voltage power grid	66	Northern Ireland-MV480	Northern Ireland medium-voltage power grid
67	Cameroon	Cameroon low-voltage power grid	68	Cameroon-MV480	Cameroon medium-voltage power grid
69	Jordan-Distribution	Jordan power distribution network low-voltage power grid	70	LEBANON	Lebanon low-voltage power grid
71	Jordan-Transmission-HV	Jordan high-voltage power grid	72	TUNISIA	Tunisia power grid

No.	Power Grid Code	Description	No.	Power Grid Code	Description
73	AUSTRALIA-NER	Australia NER standard power grid	74	SAUDI	Saudi Arabia power grid
75	Israel	Israel power grid	76	Chile-PMGD	Chile PMGD project power grid
77	VDE-AR-N4120_HV	VDE4120 standard power grid	78	VDE-AR-N4120_HV480	VDE4120 standard power grid (480 V)
79	Vietnam	Vietnam power grid	80	Custom (50 Hz)	Reserved
81	Custom (60 Hz)	Reserved	82	Custom-MV480 (50 Hz)	Reserved
83	Custom-MV480 (60 Hz)	Reserved	N/A	N/A	N/A

Appendix 3: Power Grid Codes (SUN2000-42KTL)

No.	Power Grid Code	Description	No.	Power Grid Code	Description
1	RD1699/661-MV480	Spain medium-voltage power grid	2	BDEW-MV480	Germany medium-voltage power grid (BDEW-MV480)
3	G59-England-MV480	England medium-voltage (I > 16 A)	4	IEC61727-MV480	IEC61727 medium-voltage power grid (50 Hz)
5	UTE C 15-712-1-MV480	France island medium-voltage power grid	6	TAI-PEA-MV480	Thailand medium-voltage power grid (PEA)
7	TAI-MEA-MV480	Thailand medium-voltage power grid (MEA)	8	EN50438-DK-MV480	Denmark medium-voltage power grid
9	EN50438-TR-MV480	Turkey medium-voltage power grid	10	C11/C10-MV480	Belgium medium-voltage power grid
11	Philippines-MV480	Philippines medium-voltage power grid	12	AS4777-MV480	Australia medium-voltage power grid
13	ANRE-MV480	Romania medium-voltage power grid	14	NRS-097-2-1-MV480	South Africa medium-voltage power grid
15	IEC61727-60 Hz-MV480	IEC61727 medium-voltage power grid (60 Hz)	16	PO12.3-MV480	Spain medium-voltage power grid
17	EN50438_IE-MV480	Ireland medium-voltage power grid (EN50438_IE)	18	KOREA-MV480	South Korea medium-voltage power grid
19	CEI0-16-MV480	Italy medium-voltage power grid (CEI0-16)	20	CEI0-21-MV480	Italy medium-voltage power grid (CEI0-21)

No.	Power Grid Code	Description	No.	Power Grid Code	Description
21	Egypt ETEC-MV480	Egypt medium-voltage power grid	22	CLC/TS50549_IE-MV480	Ireland medium-voltage power grid (CLC/TS50549_IE)
23	Jordan-Transmission-MV480	Jordan medium-voltage power grid	24	SA_RPPs-MV480	South Africa medium-voltage power grid
25	ZAMBIA-MV480	Zambia medium-voltage power grid	26	Chile-MV480	Chile medium-voltage power grid
27	Mexico-MV480	Mexico medium-voltage power grid	28	Malaysian-MV480	Malaysia medium-voltage power grid
29	KENYA_ETHIOPIA_MV480	Kenya medium-voltage and Ethiopia medium-voltage power grid	30	NIGERIA-MV480	Nigeria medium-voltage power grid
31	DUBAI-MV480	Dubai medium-voltage power grid	32	Northern Ireland-MV480	Northern Ireland medium-voltage power grid
33	Cameroon-MV480	Cameroon medium-voltage power grid	34	Jordan-Distribution-MV480	Jordan power distribution network medium-voltage power grid
35	NAMIBIA_MV480	Namibia power grid	36	LEBANON-MV480	Lebanon medium-voltage power grid
37	Jordan-Transmission-HV480	Jordan high-voltage power grid	38	TUNISIA-MV480	Tunisia medium-voltage power grid
39	AUSTRALIA-NER-MV480	Australia NER standard power grid	40	SAUDI-MV480	Saudi Arabia power grid
41	Ghana-MV480	Ghana medium-voltage power grid	42	Israel-MV480	Israel power grid
43	Chile-PMGD-MV480	Chile PMGD project power grid	44	VDE-AR-N4120_HV480	VDE4120 standard power grid (480 V)
45	Vietnam-MV480	Vietnam power grid	46	Custom-MV480 (50 Hz)	Reserved
47	Custom-MV480 (60 Hz)	Reserved	N/A	N/A	N/A

 **NOTE**

Grid codes are subject to change. The listed codes are for your reference only.

Huawei Technologies Co., Ltd.
Huawei Industrial Base, Bantian, Longgang
Shenzhen 518129 People's Republic of China
www.huawei.com